

A

B

C

D

E

F

A

B

C

D

E

F

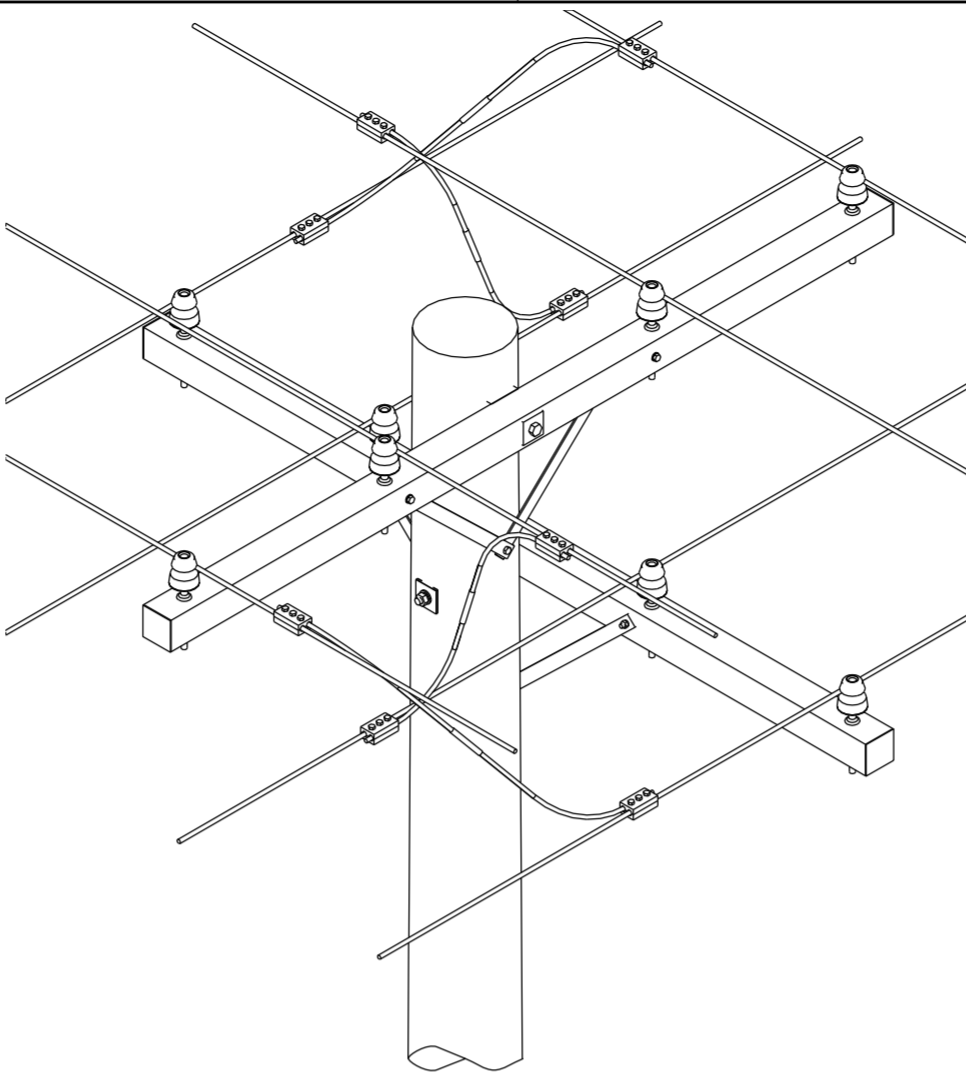
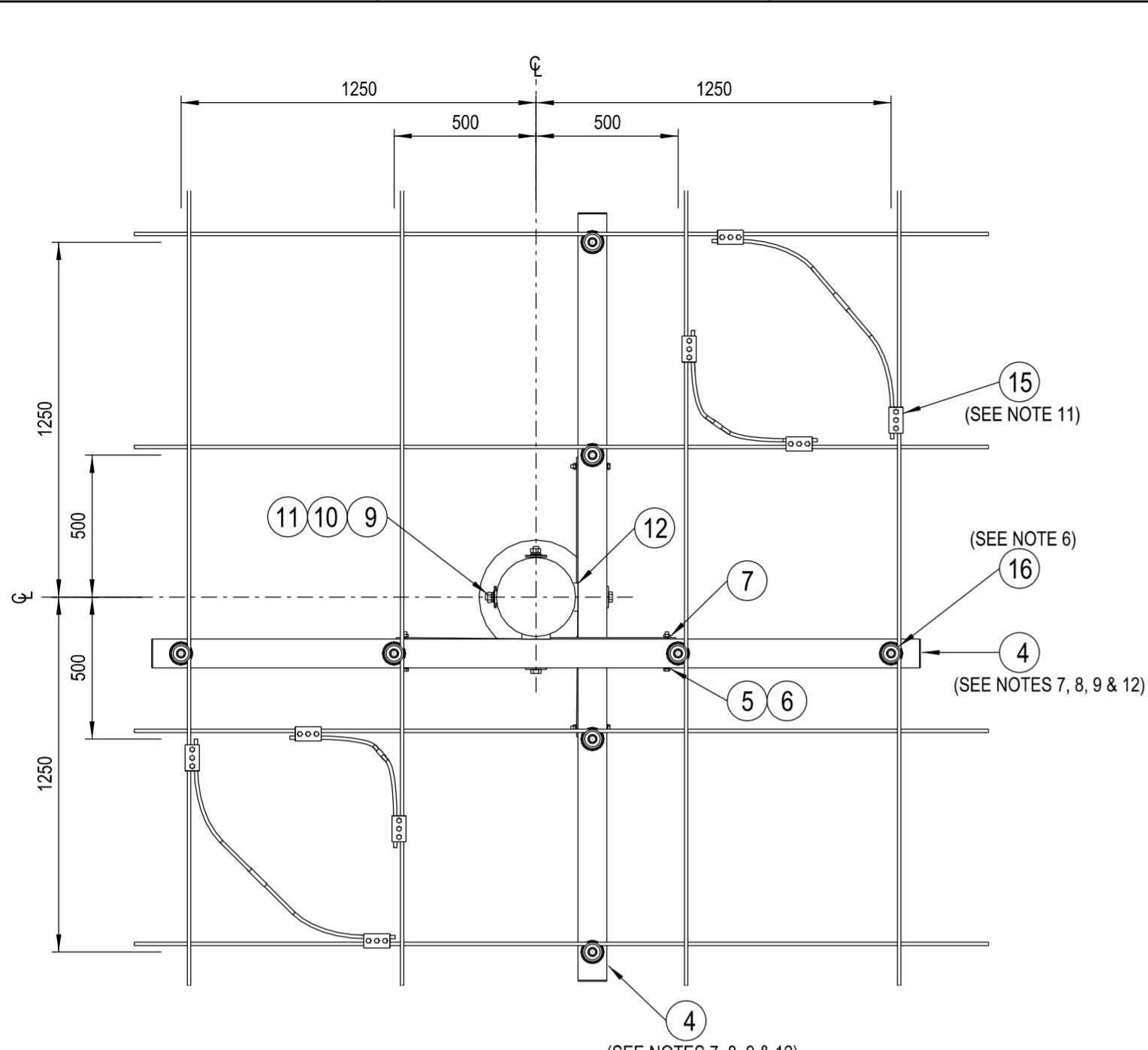

**NOTES :**

1. THE FOLLOWING INFORMATION IS OBTAINED FROM THE PROJECT DESIGN DRAWINGS:
  - a. POLE LENGTH AND STRENGTH.
  - b. SPECIAL FOUNDATION REQUIREMENTS.
  - c. POLE EMBEDMENT DEPTH.
  - d. CONDUCTOR SIZE.
  - e. CROSSARM SIZE AND BRACE REQUIREMENTS.
  - f. STAY REQUIREMENTS.
  - g. DEVIATION ANGLE.
2. ALL BOLTS AND INSULATOR PINS PASSING THROUGH TIMBER ARE TO BE COATED WITH GRAPHITE GREASE.
3. THE MAXIMUM LINE DEVIATION ANGLE TO BE CONSTRUCTED ON THIS ARRANGEMENT IS TO BE DETERMINED BY THE LINE DESIGNER.
4. POLES SHALL BE DRILLED, SCARFED AND DRESSED ON SITE. DRILLING AND SCARFING TO BE TREATED WITH APPROVED PRESERVATIVES.
5. POLE STEPS ARE TO BE INSTALLED IN ACCORDANCE WITH THE REQUIREMENTS OF NS128.
6. IF THE CONDUCTOR DEVIATES AT THE INSULATOR, USE THE ANGLE TYPE CONDUCTOR TIE ARRANGEMENT. OTHERWISE, USE THE INTERMEDIATE TYPE CONDUCTOR TIE ARRANGEMENT AS SHOWN ON DRG: 514044.
7. COMPOSITE FIBRE CROSSARMS ARE TO BE USED AS THE PREFERRED OPTION UNDER NORMAL CIRCUMSTANCES.
8. A 2706mm COMPOSITE FIBRE CROSSARM IS TO BE USED AS THE DEFAULT CROSSARM. FOR NARROW FEEDER ALIGNMENTS, A SHORTER CROSSARM MAY BE CONSIDERED TO OVERCOME DESIGN AND SITE CONSTRAINTS.
9. ONLY THE 2706mm COMPOSITE FIBRE CROSSARM OPTION IS SHOWN ON THIS CONSTRUCTION DRAWING. REFER TO DRGS: 262732, 514373, 15233 & 514374 FOR DRILLING PATTERN OF ALTERNATE CROSSARMS.
10. THE 690mm CROSSARM BRACES ARE TO BE USED ON A 2706mm, 2106mm, 2700mm & 2100mm CROSSARM. THE 490mm CROSSARM BRACES ARE TO BE USED ON A 2406mm & 2400mm CROSSARM.
11. BI-METALLIC PARALLEL GROOVE CLAMPS ARE NOT TO BE INSTALLED ON TENSIONED CONDUCTORS. IF JOINING ALUMINIUM AND COPPER CONDUCTORS, A PARALLEL GROOVE CLAMP AND CONDUCTOR TAIL TO SUIT THE TENSIONED CONDUCTOR MATERIAL IS TO BE INSTALLED. THE ALUMINIUM AND COPPER CONDUCTORS ARE JOINED WITH A BI-METALLIC COMPRESSION LINK INSTALLED IN THE NON-TENSIONED CONDUCTOR TAPPING.
12. FOR DETAILS OF APPROVED ALTERNATE WAGNER COMPOSITE FIBRE CROSSARMS, REFER TO DRG: 265964.
13. REFER TO DESIGNER SAFETY REPORT D23/224142 FOR ATYPICAL HAZARDS ASSOCIATED WITH THIS STANDARD CONSTRUCTION.

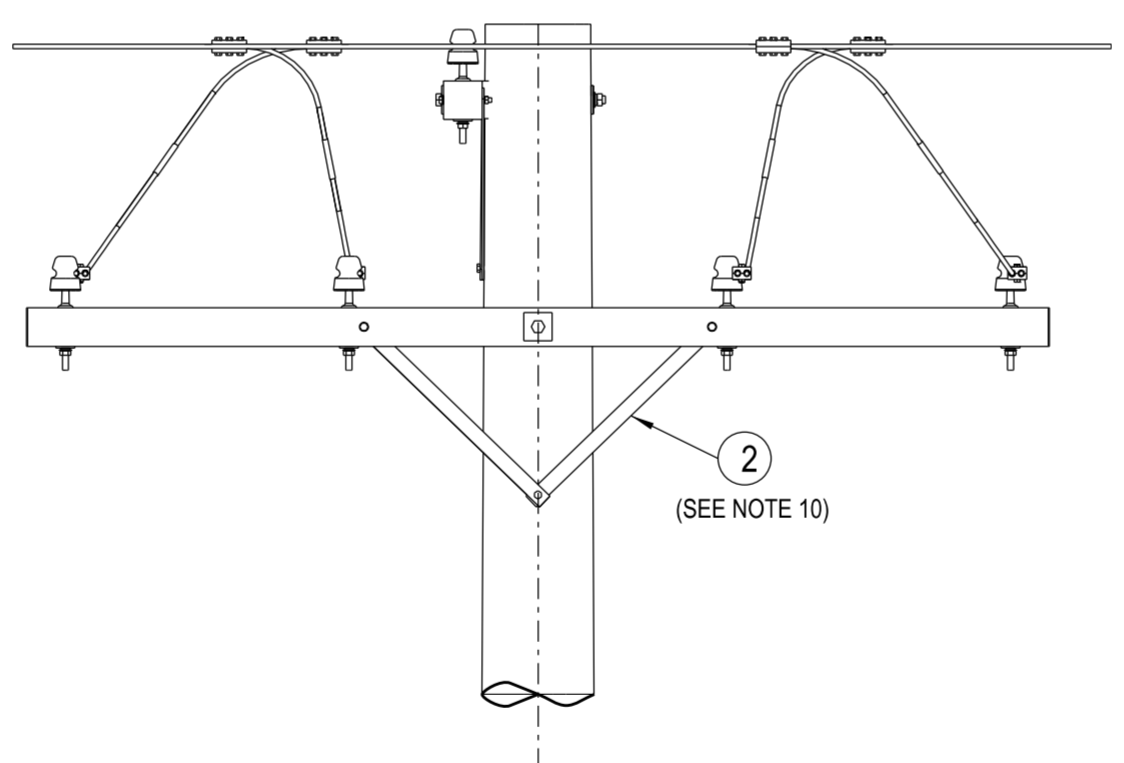
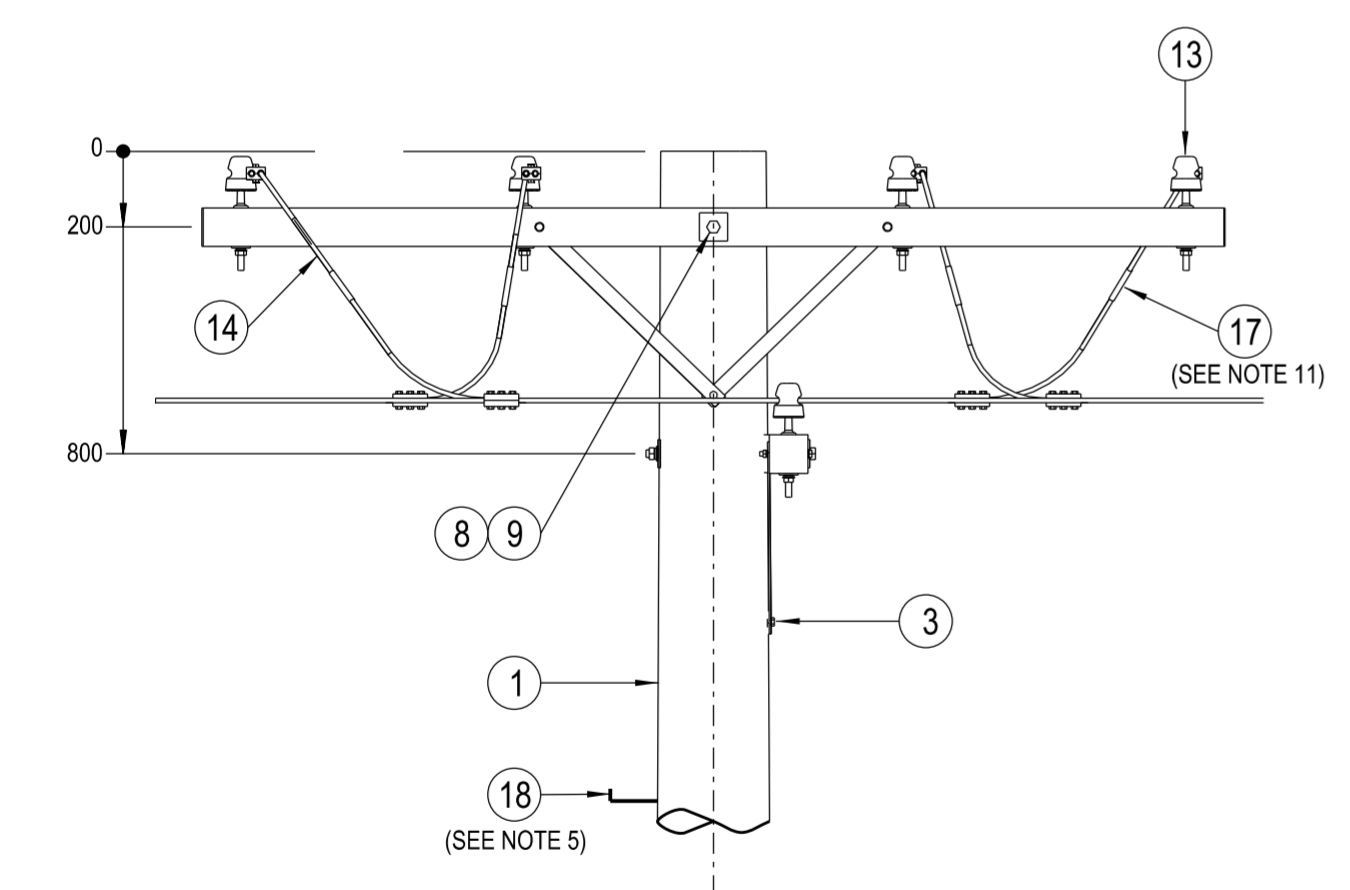

18	STEP - POLE, SCREW-IN (SEE NOTE 5)	250144	185198	A/R
17	LINK - BI-METALLIC, COMPRESSION (TO SUIT CONDUCTORS) (SEE NOTE 11)	514053		4
16	TIE - CONDUCTOR, LOW VOLTAGE, SUPPORT ARRANGEMENT (SEE NOTE 6)	514044		5m
15	CLAMP - PARALLEL GROOVE (TO SUIT CONDUCTOR) (SEE NOTE 11)	514099		8
14	CONDUCTOR - OVERHEAD, COVERED, TAPPING (TO SUIT OVERHEAD CONDUCTORS)			4m
13	INSULATOR - LV, (LPLV PATTERN 'B') & PIN ARRANGEMENT	513995		8
12	BLOCK - GAIN, ALUMINIUM, 100mm		146274	2
11	WASHER - FLAT, M20, GALVANISED	518081	177986	2
10	WASHER - CONICAL, M20, GALVANISED	518082	H39655	2
9	WASHER - SQUARE, 75x75x6mm, GALVANISED (Ø22mm HOLE)	518081	H39231	4
8	BOLT & NUT - M20, HEX., GALVANISED (LENGTH TO SUIT POLE)	515466		2
7	WASHER - CONICAL, M12, GALVANISED (USE WITH HARDWOOD CROSSARMS)	518082	H39639	4
	WASHER - SPRING, M12, GALVANISED (USE WITH COMPOSITE FIBRE CROSSARMS)	518082	H12047	
6	WASHER - FLAT, M12, GALVANISED	518081	177982	8
5	BOLT & NUT - M12x130mm, HEX., GALVANISED	515466	46805	4
4	CROSSARM - 2100x100x100mm, TYPE A, HARDWOOD (SEE NOTES 7, 8, 9 & 12)	514374	H23818	2
	CROSSARM - 2400x100x75mm, TYPE L3, HARDWOOD (SEE NOTES 7, 8, 9 & 12)	15233	89912	
	CROSSARM - 2700x100x100mm, TYPE D, HARDWOOD (SEE NOTES 7, 8, 9 & 12)	514373	H23868	
	CROSSARM - 2106x102x102mm, TYPE 1, COMPOSITE FIBRE (SEE NOTES 7, 8, 9 & 12)	262732	186771	
	CROSSARM - 2406x102x102mm, TYPE 2, COMPOSITE FIBRE (SEE NOTES 7, 8, 9 & 12)	262732	186772	
	CROSSARM - 2706x102x102mm, TYPE 3, COMPOSITE FIBRE (SEE NOTES 7, 8, 9 & 12)	262732	186773	
3	SCREW - COACH, M12 x 100mm, GALVANISED		H40484	2
2	BRACE - CROSSARM, FLAT, TYPE L, 490mm, GALVANISED (SEE NOTE 10)	46	76745	4
	BRACE - CROSSARM, FLAT, 690mm, GALVANISED (SEE NOTE 10)	514385	H17738	
1	POLE - TIMBER (AS REQUIRED)	513988		1

ITEM	DESCRIPTION	DRG. No	STOCK CODE	QTY
------	-------------	---------	------------	-----

ALL DIMENSIONS IN MILLIMETRES UNLESS NOTED OTHERWISE. DO NOT SCALE.

NO.	DESCRIPTION	DRG. No
1	COMPOSITE FIBRE CROSSARMS WAGNER SPECIFICATION	265964
2	2700mm CROSSARMS FOR LV, 11kV, 22kV & 33kV CONSTRUCTION DETAILS	514373
3	COMPOSITE FIBRE CROSSARMS SPECIFICATION	262732
4	LV CONDUCTOR TIE & SUPPORT ARRANGEMENTS	514044
5	WOODEN CROSSARMS FOR 415V OVERHEAD MAINS	15233
6	WOODEN CROSSARMS FOR LV, 11kV & 33kV CONSTRUCTION DETAILS	514374

NETWORK STANDARD  
**Ausgrid**  
 145 NEWCASTLE RD WALLSEND, NSW 2287

SCALE	1:20	STANDARD CONSTRUCTION LV CORNER POLE 4 WAY THROUGH CONSTRUCTION 1-13
DESIGNED	-	
DRAWN	M.L	
CHECKED	P.J	
APPROVED	R.BREMELL	
DATE	15/03/1996	
PROJECT NUMBER	STD	
PROJTRAK NUMBER	-	
SIZE	A2	DRAWING No
		513905
		SHEET
		1
		AMD
		12