

No.	DESCRIPTION	STOCK	QTY	
			ARR-1	ARR-2
1	CONNECTOR - SPLICE IPC 6-25 AL/CU INSULATED (HSC)	H109686	3	3
2	CLAMP - CABLE STRAIN 2-4 CORE 6-25mm ²	H102491	1	1
3	CABLE - 4x25mm ² AL ABC XLPE	H109280	A/R	A/R
4	EYENUT - M12, GALVANISED	H39281	1	-
	HOOK - Q TYPE, DRG : 117807	128934	-	1
5	WASHER - SQUARE 50x50x6mm Ø16 HOLE GALVANISED	175563	1	-
6	NUT - M12 GALVANISED	9118	2	2
7	BOLT - M12x40mm, GALVANISED, HEX	46375	1	1
8	RAISER BRACKET (AS PER SERVICE & INSTALLATION RULES OF NSW)		1	1
9	SADDLE		1	1
10	CONSUMER MAINS	-	1	1
11	CONNECTOR - SPLICE FOR NEUTRAL PHASE, 6-25 Al/Cu INSULATED SERVICE	182906	1	1

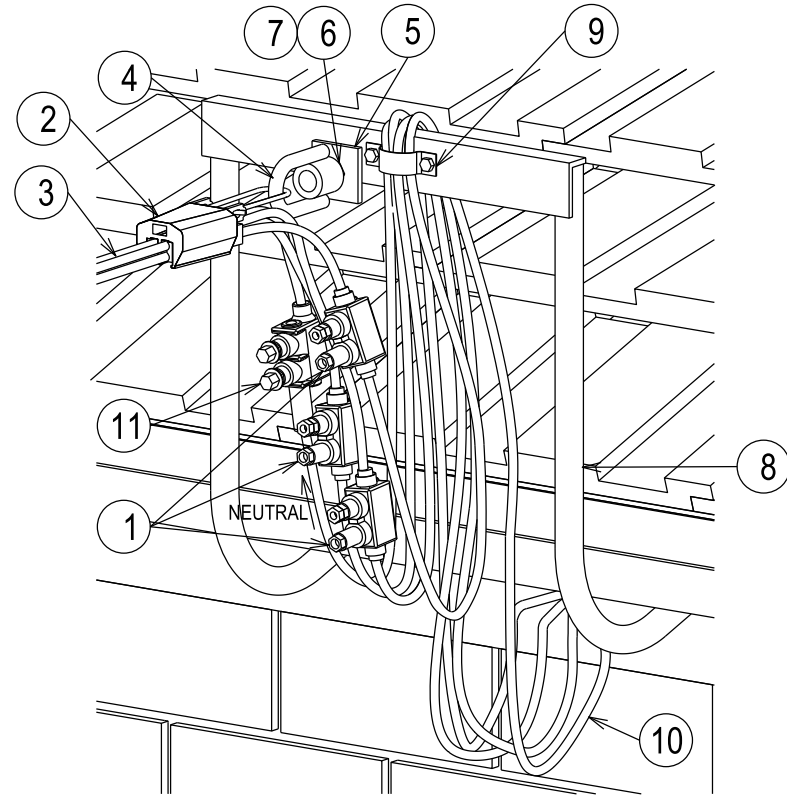

ARR-1

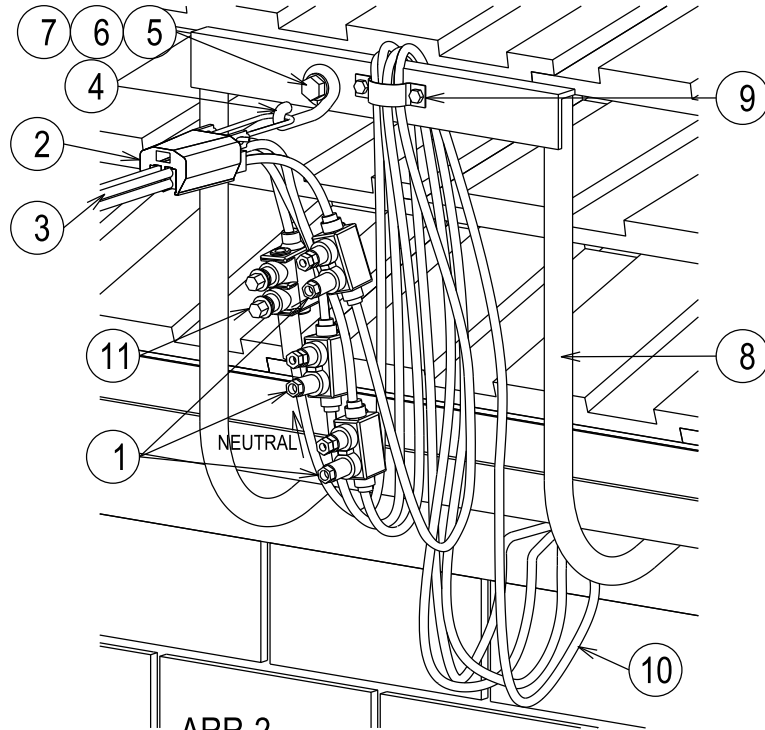

ARR-2

CAD DRAWING
DO NOT MANUALLY AMEND
AMENDMENTS
DWN: PATRICIA RIOS
CHKD: HIRI EHAMPARAM
DATE: 05/05/2014
NEUTRAL CONNECTION
CHANGED, MATERIAL
LIST AMENDED.
6
APPD: MATTHEW CUPPLES

NETWORK STANDARD
Ausgrid
145 NEWCASTLE RD
WALLSEND NSW 2287
PHONE: 4951 9388
FAX: 4591 9389

DESIGNED	ROBERT KNOWLES
DRAWN	PATRICIA RIOS
CHECKED	ROBERT KNOWLES
AUTHORISED	GREG SKINNER
DATE	02/07/04
SCALE	NTS
MAP REF.	
LGA	

STANDARD CONSTRUCTION
100AMP HOUSE SERVICE CONNECTION
3 PHASE - RAISER BRACKET

PROJECT No. NET-STD

PROJTRAK No. -

Sheet 01 of 1 Sheets

A4 152494 6