

1

2

3

4

5

6

7

8

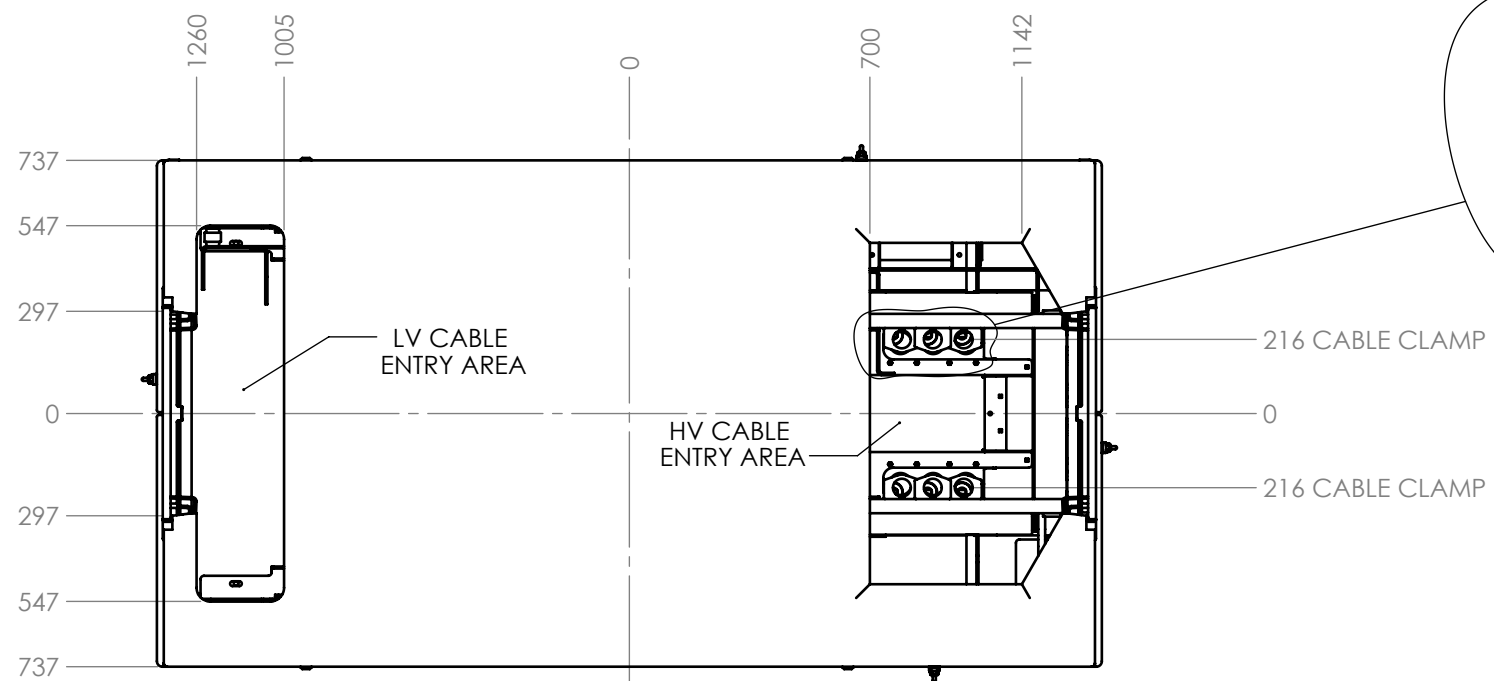
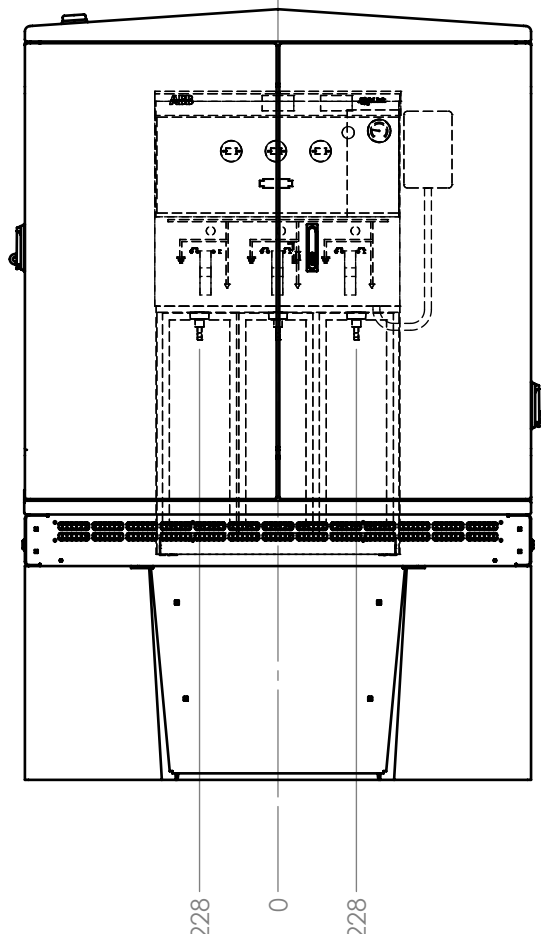
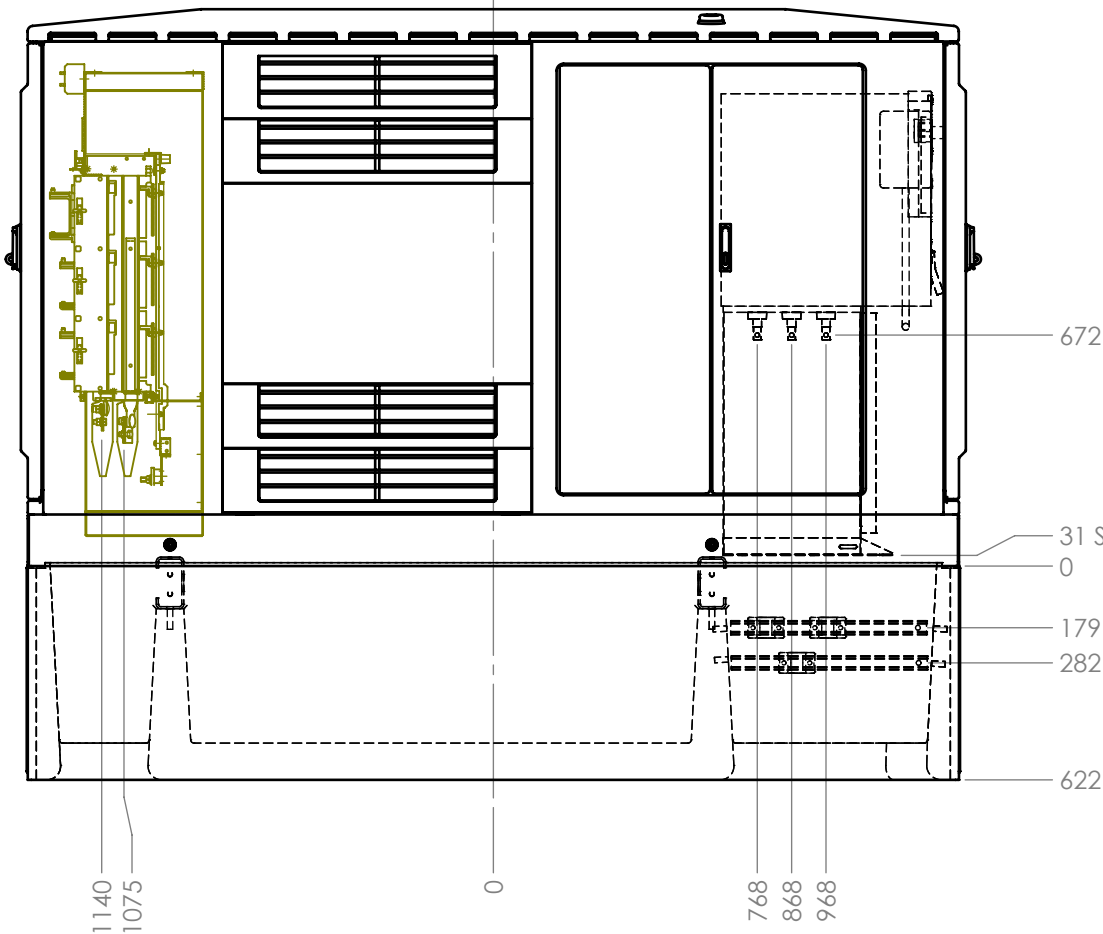
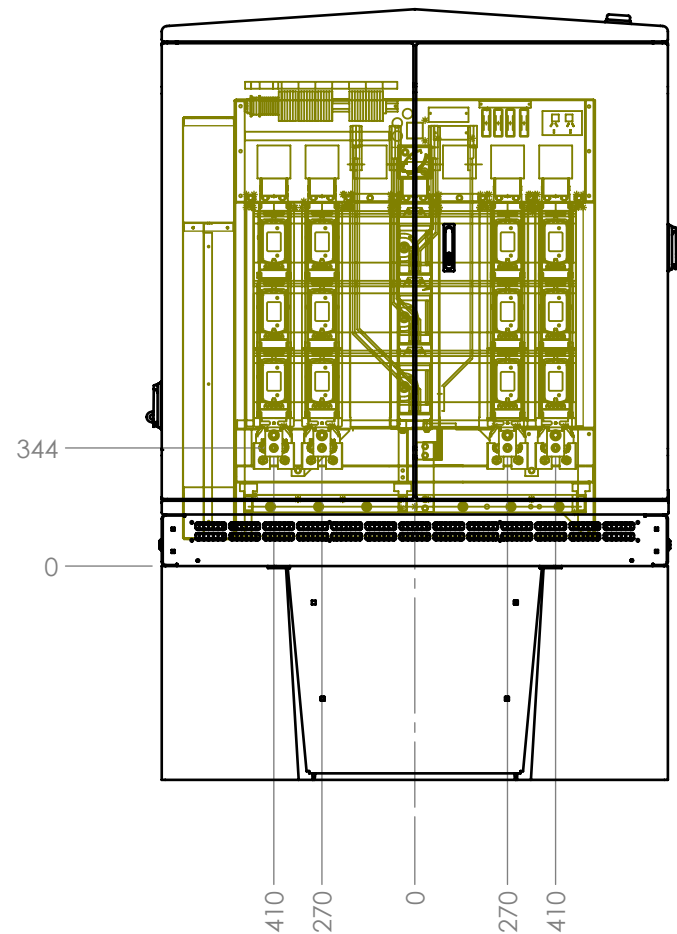

Ø 64 SUIT
MAIN CABLE GLANDS

**REMOVABLE
SPLIT GLAND PLATE DETAIL**

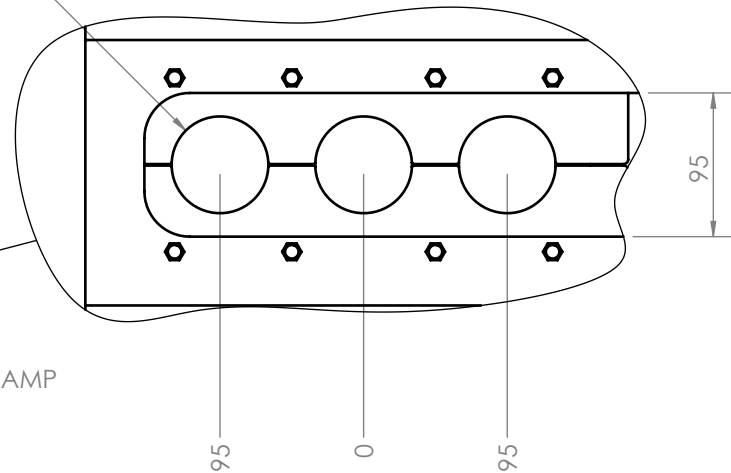

238568_03R00

FINISH: N/A

SHEET SIZE A3

**THIRD
ANGLE
PROJ.**

All Welds to conform to AS 1554 sections 1 to 6, Cat.GP & 2B, unless specified otherwise.

Min Weld Size	Thickness of thinnest part	Min.weld size
≤ 6mm	≤ 6mm	Thinnest mat. thickness
> 6mm to 8 mm	> 6mm to 8 mm	6 mm
> 10 mm	> 10 mm	Thinnest mat. less 2 mm

Butt weld DDT to be "Incomplete penetration butt weld"

TOLERANCE UNLESS OTHERWISE STATED

LINEAR	ANGULAR
1 ±1 (0-2000)	1 ±1°
1 ±3 (>2000)	1.0 ±1°
1.0 ±0.5	1.00 ±0.05°
1.00 ±0.05	



**WILSON
TRANSFORMER
CO. PTY. LTD.
ACN 004 216 979**

DESCRIPTION

KIOSK TRANSFORMER 800kVA

SCALE 1:22 PAGE 3 OF 4 FILE NO. **881-A008-11**

ALL DIMENSIONS ARE IN mm UNLESS OTHERWISE STATED

REV **U**